



**NEW
PRODUCT**

Designed for fracture mechanics testing in environmental chambers

where the entire gage must be exposed to elevated temperatures.

These capacitive sensors may be used up to 700 °C (1300 °F) without

any cooling.

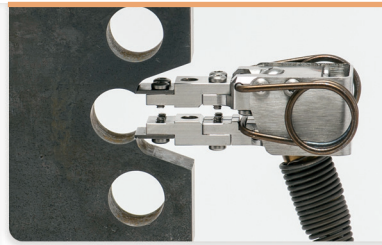

Model 7641 COD gage

These COD gages use a high-temperature capacitive sensor and do not require any cooling. They will operate up to the maximum temperature limit of most environmental chambers used in materials testing.

The Model 7641 is ideal for determination of fracture mechanics parameters such as JIC, KIC, R-curve, fatigue crack growth rate (da/dN), and testing to standards such as E1820, E399, E647, etc. All units can be displaced slightly in compression for ease of installation.

The COD gage is supplied with the advanced DT6229 controller. The standard output is 0-10VDC analog signal, factory calibrated with the COD gage. This system provides a number of functional enhancements, including: high speed digital output, built in calibration and tare functions, analog and digital filters, and more.

The 7641 is readily interfaced with most existing test controllers, and may be directly connected to a data acquisition system or chart recorder, or directly to a PC. The 7641 may be used for strain controlled tests such as JIC.

See the electronics section of this catalog for available signal conditioners and strain meters.



Model 7641 COD gage



Model 7641 COD gage with signal conditioner

Features

- **May be left on through specimen failure.**
- Improved performance at high temperature.
- Improved noise rejection, resolution, and accuracy.
- Improved clearance with most clevis designs.
- Improved linearity and reduced stiffness.
- Reduced size and weight, and improved high frequency performance.
- All standard models are suitable for cyclic testing.
 - >25 Hz is typical for 10mm GL and larger, up to 100 Hz for some configurations
 - Typically limited by the user's test apparatus, software settings, and filter selection
- Digital controller and power supply included. Provides high level DC voltage output with low noise. Easily interfaced to test controllers, data acquisition boards and chart recorders.
 - Includes high speed analog and digital outputs
 - Intuitive web-based user interface for setup, calibration, and data acquisition
 - Built-in calibration reference and auto-zero features
 - Multiple extensometer calibration files may be loaded for use with one controller
 - Multiple temperature-specific calibrations may be stored
 - Selectable analog and digital filter options from 2 Hz to 3 kHz
- Ships fully calibrated with electronics (traceable to NPL (UK)) with user specified voltage output.
- Mechanical over-travel protection.
- All standard units meet ASTM E1820, ASTM E399, ISO 12135, and ISO 9513 Class 1 requirements for accuracy. A test certificate for ASTM E1820 is included. ASTM E399 or ISO 12135 test certificates are available upon request.
- Durable stainless steel knife edges.
- Includes high quality foam lined case.
- Rugged, dual flexure design for strength and improved performance. The next-generation design enables cyclic testing at much higher frequencies.

SPECIFICATIONS

<i>Analog Output:</i>	User specified, +/-5 VDC or +/-10VDC typical, ±10.8VDC rail
<i>Digital Output:</i>	24 bit high speed Ethernet output with built-in web interface
<i>Linearity:</i>	11 point linearization, ≤0.1% FS typical linearity
<i>Resolution:</i>	<55 PPM (0.006%FS) RMS@4 kHz, <6 PPM (0.0006%FS)@100 Hz
<i>Cyclic Testing:</i>	>25 Hz typical@10mm GL, >10 Hz@5mm GL
<i>Analog Filter:</i>	Selectable 100 Hz analog and 2 Hz - 3 kHz digital filters
<i>Temperature Range:</i>	Ambient to 700 °C (1300 °F). Use up to 800 °C is possible – contact Epsilon for details. Springs may require periodic adjustment or replacement after long-term testing above ~600 °C.
<i>Temperature Sensitivity (Gain):</i>	<100 PPM/°C (0.01%FS/°C) typical
<i>Temperature Sensitivity (Offset):</i>	20 PPM/°C (0.002%FS/°C) typical
<i>Sensor Cable:</i>	0.7 m (2.5 ft.) tri-axial high temperature cable, plus 1.5 m (5 ft) room temperature extension cable
<i>Operating Force:</i>	1-5 kg typical, depending on model
<i>Environment:</i>	Recommended for elevated temperature testing in dry air, inert / non-corrosive gases, or vacuum
<i>Power:</i>	Includes power supply for your country (specify)

OPTIONS

- Connectors to interface to nearly any brand test equipment
- Bulkhead adapters for vacuum chambers
- Bolt on knife edges for attachment to test specimens without machined attachment points

ORDERING INFORMATION

Model 7641 Available Versions: ANY combination of gauge length and measuring listed below is available, except as noted. *Other configurations may be available with special order; please contact Epsilon to discuss your requirements.*

Gauge Length		Measuring Range	
U.S.A.		U.S.A.	
-0020	0.20"	-010T ²	+0.10" *
-0025	0.25"	-025T	+0.25" **
-0040	0.40"	-040T	+0.40" **
-0050	0.50"	-050T	+0.50" **
METRIC		METRIC	
-003M ¹	3.0 mm	-025M ²	+2.5 mm *
-005M	5.0 mm	-040M	+4.0 mm *
-006M	6.0 mm	-060M	+6.0 mm **
-010M	10.0 mm	-080M	+8.0 mm **
-012M	12.0 mm	-100M	+10.0 mm **
		-125M	+12.5 mm **

Model Number 7641- _____ - _____

¹ Special order, <5 Hz typical

² Suitable for front-face mounting only

* Tilted cable exit

** Vertical cable exit

Example: 7641-010M-060M: 10.0 mm gauge length, +6.0 mm measuring range

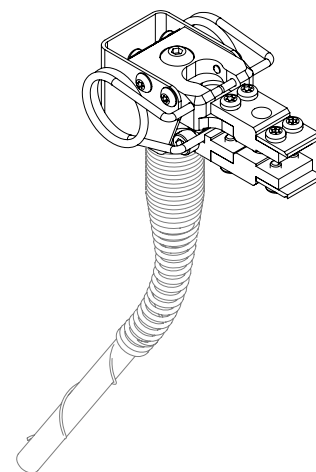

MODEL 7641 EXAMPLE